

10201-30999 ON DRG. NO.

12.5 ALL OVER UNLESS OTHERWISE STATED

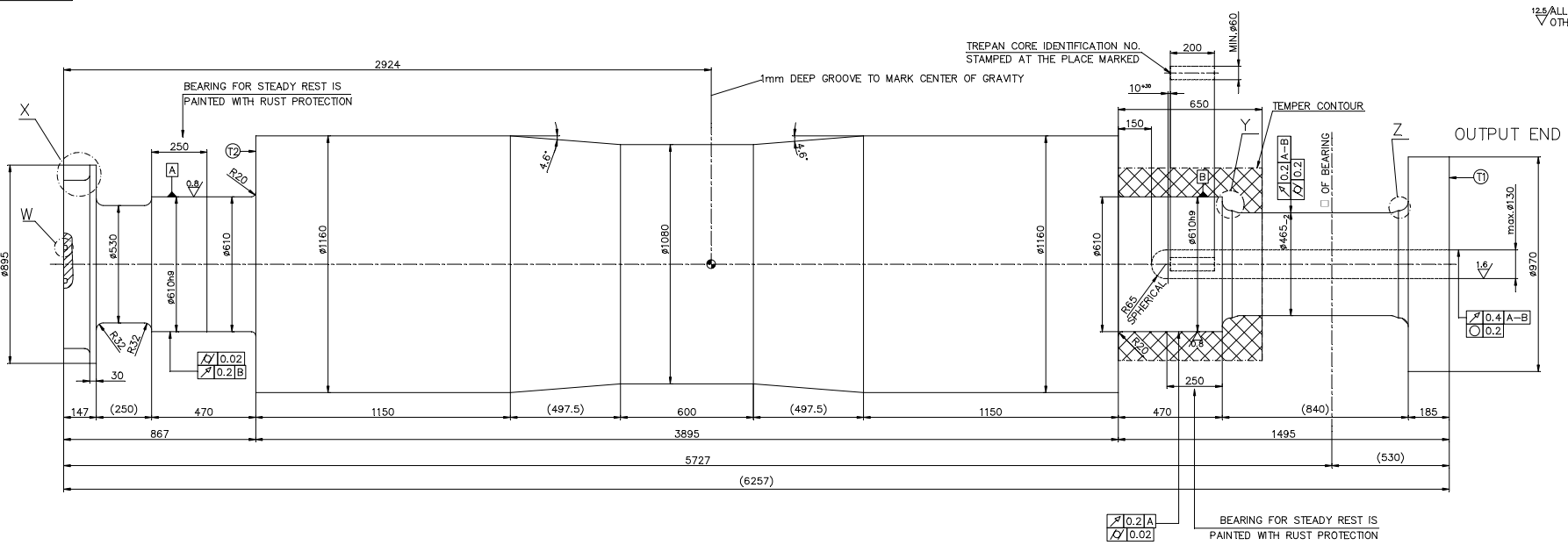

TECHNICAL REQUIREMENTS:-

- FORGING SHALL BE SUPPLIED IN ROUGH MACHINED CONDITION AS PER SPEC. NO. HW19468
- PERMISSIBLE TOLERANCES :-
ON INSIDE DIMENSION: -2.
ON OUTSIDE DIMENSION: +2.
- BRACKETED DIMENSION ARE FOR REFERENCE ONLY.
- AT THE PLACE MARKED (T) AND (T2) SUPPLIER SHALL LOCATE THE TANGENTIAL TEST SAMPLE FOR MECHANICAL TESTING. PART OF THE TEST SAMPLE (≈ 40mm) SHALL BE LEFT INTEGRAL WITH THE SHAFT FOR BHEL.
- AXIAL CORE SHALL BE TREPANED AFTER SATISFACTORY TESTING OF (T), (T2) AND ULTRASONIC TEST. TESTING OF AXIAL CORE IS TO BE DONE AS PER SPECIFICATION AA0850155. BALANCE OF AXIAL CORE DULY MARKED WITH IDENTIFICATION NUMBER SHALL BE DENT TO BHEL ALONG WITH ROTOR.
- AFTER SATISFACTORY TESTING OF AXIAL CORE THE ROTOR PORTION SHOWN AS ~~XXXXXX~~ IS TO BE MACHINED OFF.
- THE IDENTIFICATION NUMBER MUST BE STAMPED AT THE PLACE MARKED WITH IN AND SUITABLY PAINTED WITH RUST PREVENTIVE.

| | |
|-------------|---------|
| WEIGHT: | |
| THEORETICAL | MAXIMUM |
| 36353KG | 37800KG |

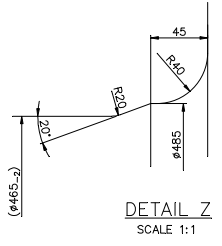
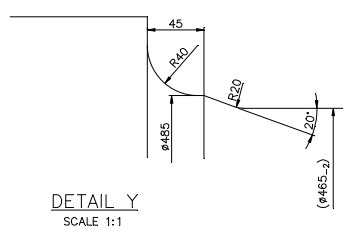
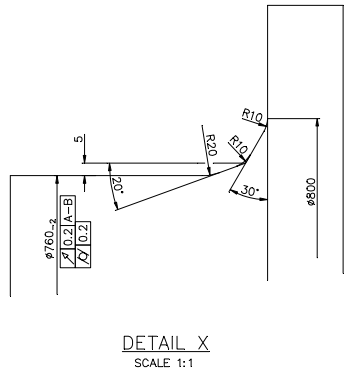
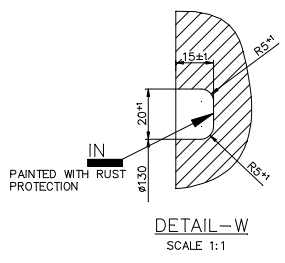

| | | | | | |
|---------------------------|----------|-------------------------------|--------------|-------------|----------------|
| FORGING FOR I.P. SHAFT | | 1-10201-30999 | W95310201262 | 36353 | 00 |
| VAR 00 | REMARKS | ITEM No. | DESCRIPTION | DRAWING No. | |
| 59 | 64 | 65 | 75 | 25 | 27 |
| 28 | 28 | 28 | 28 | 28 | 28 |
| GRADE OF UNTOLDIM | | STEAM TURBINE | | | |
| M/CC.-G/M/F AA0230208 | | NAME OF CUSTOMER/PROJECT | | | |
| WELDING-R/B/G/P AA0621104 | | BHARAT HEAVY ELECTRICALS LTD. | | | |
| GAS CUTTING-T3'AA0621101 | | RANIPUR, HARDWAR | | | |
| REV | DATE | ALTERED | REV | DATE | ALTERED |
| 01 | 06.06.23 | RAJ.PAL sd/- | 01 | 03.01.17 | MINENDRA -sd/- |
| | | CHEKED/SUBODH sd/- | | | TX |
| TECH.REQ.T. NO.5 MODIFIED | | DEPT MTE | | | |
| C/A. NO. MTE-23-F0021 | | CODE4300 | | | |
| | | SCALE 1:10 | | | |
| | | WEIGHT (KG) 36353 | | | |
| | | REF. TO ASSY. DRG. | | | |
| | | DRAWING NO. 1-10201-30999 | | | |
| | | CARD CODE 22/23 24 | | | |
| | | SHEET No. 01 No. Of SHEETS 01 | | | |

THE INFORMATION ON THIS DOCUMENT IS THE PROPERTY OF BHARAT HEAVY ELECTRICALS LIMITED. IT MUST NOT BE USED DIRECTLY OR INDIRECTLY IN ANY WAY DETRIMENTAL TO THE INTEREST OF THE COMPANY